



Section **M**

5/2008



Ford Bolted Flex Couplings

The Ford Meter Box Company, Inc.

775 Manchester Avenue, P.O. Box 443, Wabash, Indiana, USA 46992-0443
Telephone: 260-563-3171 FAX: 800-826-3487 Overseas FAX: 260-563-0167
<http://www.fordmeterbox.com>



Contents

Bolted Flex Coupling Numbering System	3
Features and Specifications of Ford Cast Couplings	4
Ford Ductile Iron Couplings, Style FC1	5
Ford Ductile Iron Transition Couplings, Style FC2A	6
Transition Coupling Parts	7
Ford Ultra-Flex Wide Range Couplings, Style FC2W	8 - 9
Ford Iron Reducing Couplings, Style FRC	10
Ford Insulating Boots, Style FIB	10
Ford Iron Flanged Coupling Adapters, Style FFCA	11
Ford Cut-in Couplings, Style FRR	12
Ford End Cap Couplings, Style FEC and FC2W-EC	13
Pipe O.D. Chart	14
Ford FC2W Ultra Flex Installation Instructions	14
Installation Instructions for Ford Flexible Couplings	15
Warranty	16

The Ford Meter Box Company, Inc. manufacturing facilities are at the following locations:

1. The Ford Meter Box Company, Inc. – Main Office
775 Manchester Avenue
P.O. Box 443
Wabash, Indiana 46992-0443
2. The Ford Meter Box Company, Inc.– Pipe Products Division
815 Miles Parkway
Pell City, Alabama 35125

For Sales and Customer Service contact:

The Ford Meter Box Company, Inc.
775 Manchester Avenue
P.O. Box 443
Wabash, IN 46992-0443

Phone: 260-563-3171

FAX: 800-826-3487 (Overseas FAX: 260-563-0167)

Ford Bolted Coupling Numbering System

TYPE OF COUPLING

- FC1** = Ductile Iron Coupling
- FC2A** = Ductile Iron Transition Coupling
- FIB** = Insulating Boot for Ductile Iron Pipe and Cast Iron Pipe
- FRC** = Iron Reducing Coupling
- FFCA** = Iron Flanged Coupling Adapter
- FRR** = Cut-in Coupling
- FEC** = End Cap Coupling
- FC2W-EC** = Wide Range Coupling with End Cap

OPTIONAL FEATURES

FOR FC1 & FC2A COUPLINGS

- SH** = Type 304 stainless steel nuts & bolts
- ESH** = Type 304 stainless steel nuts & bolts with epoxy coated coupling
- N** = NBR (Buna-N) gaskets, alloy bolts & nuts with shop coated coupling
- BBN** = Blue fluorocarbon coated nuts & bolts

FOR FFCA COUPLING ADAPTERS

- AS2** = Two anchor studs
- AS4** = Four anchor studs

(316 Stainless Steel Nuts and Bolts available - contact factory)

FC1 - 663 - 720 - SH

↑
one end

↑
other end

OD SIZE

Use listed catalog sizes

NOTE: For most coupling types each number indicates top end of range, only FC1 and FC2A have an OD size for each coupling end.

Note: See item listings in catalog section to assure that desired sizes and options are available.

TYPE OF COUPLING

FC2W = Ductile Iron Wide Range Coupling (Epoxy coated, NBR (Buna-N) gaskets)

FC2W - 6 - SH

NOMINAL PIPE SIZE

- 4** = 4"
- 6** = 6"
- 8** = 8"
- 10** = 10"
- 12** = 12"

OPTIONAL FEATURES

- SH** = Type 304 stainless steel nuts and bolts
- L12** = 12" long center sleeve
- EPDM** = EPDM gasket
- EC** = End Cap with 2" FIP threaded boss

(316 Stainless Steel Nuts and Bolts available - contact factory)



Ford offers more than 10,000 products that are Classified by Underwriters Laboratories Inc. to ANSI/NSF Standard 61. To verify if a product is Classified by Underwriters Laboratories Inc. to ANSI/NSF Standard 61, contact the Ford Meter Box Customer Service Department at 260-563-3171 or visit fordmeterbox.com and look for the LXI approved product listing. Ford's LXI Approved Bolted Flex Couplings are available at no additional cost. Ford Meter Box meets your need for ANSI/NSF Standard 61 Approved items with products that are proven and reliable. Look for LXI on the product label.



Information

Features of Ford Cast Couplings

Ford Cast Couplings offer an easy and economical way of joining pipe whether the pipe is of the same nominal size and/or type or different at each coupling end. Ford FC1 and FC2A Couplings offer the following quality features:

Ford Bolted Flex Couplings as listed in Catalog Section M are manufactured in accordance with the design, testing and performance standards of AWWA C219-01.

Bolts and Nuts are low alloy per ASTM 242 and AWWA C111. Optional stainless steel also available.

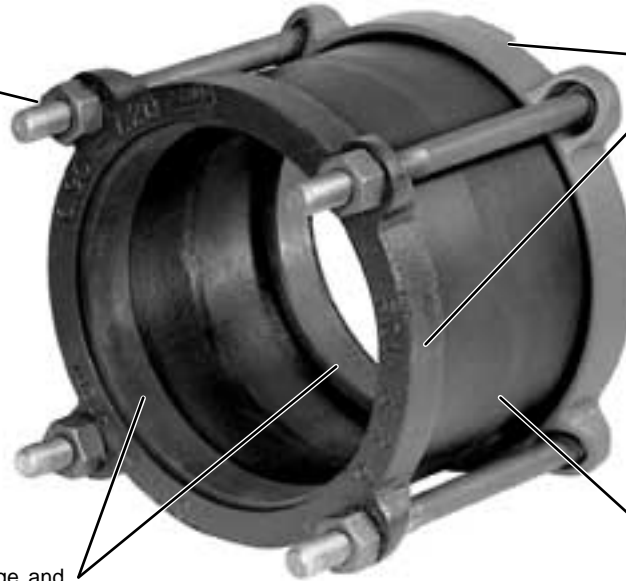

End Rings color coded to match correct gaskets. One End Ring and gasket combination will fit standard PVC and Ductile Iron Size PVC in 4", 6" and 8" nominal sizes.



**LXI Products meet
ANSI/NSF Standard 61
see page 3**

Gaskets identified with range and End Ring Color Coded

Center Sleeve optimized to accommodate a variety of pipe sizes.

Caution: Restrain if necessary to provide thrust resistance. Flexible couplings do not prevent axial pipe movement.

Specifications:

Ford Bolted Flex Couplings as listed in Catalog Section M are manufactured in accordance with the design, testing and performance standards of AWWA C219-01.

1. **Center Sleeve** - Cast from Ductile Iron per ASTM A536 65-45-12.
2. **End Rings** - Cast from Ductile Iron per ASTM A536 65-45-12. End rings are color coded for easy identification.
3. **Gaskets** - SBR rubber per ASTM D2000 90M 4AA 810. Gaskets have size and end ring color code embossed for easy identification. Optional armored gaskets are available on Style FC1 and Style FC2A in 4" thru 12" nominal pipe sizes. Optional NBR (Buna-N) or EPDM gaskets are available.
4. **Bolts and Heavy Hex Nuts** - High strength low alloy per ASTM A242 and AWWA C111. Optional blue fluorocarbon coating available. Optional stainless steel also available.
5. **Finish** - Shop coat. Optional epoxy coating is available.

Typical Uses for Ford Cast Couplings

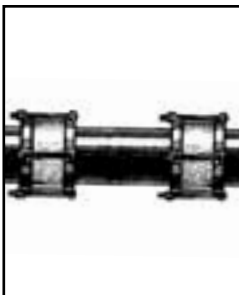

To repair split pipe

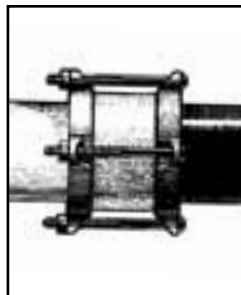

To couple different types of pipe

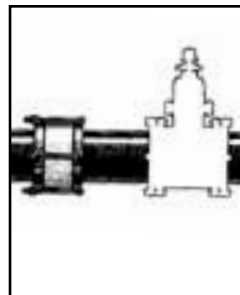

To install (cut-in) hydrants and valves

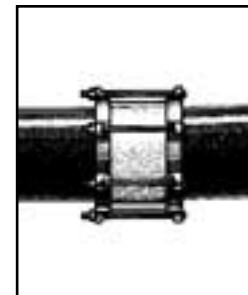

To connect misaligned pipe



LXI Products meet
ANSI/NSF Standard 61
see page 3

Ford Couplings

Style FC1

Suggested uses for Ford FC1 Couplings include water main repair, joining of plain end pipe, valve and hydrant installation, and flexible joint installation at critical areas of water main stress.

The FC1 Couplings are constructed entirely of ductile iron components permitting a strong, durable connection.

Only the FC1 offers one gasket and end ring that fits all PVC and ductile iron pipe in the most popular sizes: 4", 6", and 8". Gasket ranges are embossed on each gasket for easy identification. End rings are color coded to match the color embossed on each gasket.

Style FC1 for Cast, Ductile Iron or PVC Pipe

NOM. PIPE SIZE	GASKET RANGE		END RING COLOR CODE	BY	GASKET RANGE		END RING COLOR CODE	CENTER SLEEVE LENGTH	NUMBER OF BOLTS	APPROX. WEIGHT LBS
	1ST. HALF CAT. No.	2ND HALF CAT. No.			1ST. HALF CAT. No.	2ND HALF CAT. No.				
2"	2.34 — 2.63		Red		2.34 — 2.63		Red	4"	2	6
2 1/2"	See 2" FC2A on next page									
4"	4.00 — 4.00		Red		4.00 — 4.00		Red	5"	3	14
	4.50 — 4.80		Red		4.50 — 4.80		Red			
	4.80 — 5.10		Black		4.80 — 5.10		Black			
6"	6.00 — 6.00		Red		6.00 — 6.00		Red	5"	4	20
	6.30 — 6.30		Red		6.30 — 6.30		Red			
	6.63 — 6.90		Red		6.63 — 6.90		Red			
	6.90 — 7.20		Black		6.90 — 7.20		Black			
8"	8.00 — 8.00		Red		8.00 — 8.00		Red	5"	5	29
	8.16 — 8.40		Red		8.16 — 8.40		Red			
	8.63 — 9.05		Red		8.63 — 9.05		Red			
	9.05 — 9.40		Black		9.05 — 9.40		Black			
10"	10.20 — 10.50		Red		10.20 — 10.50		Red	6"	6	41.5
	10.75 — 10.75		Red		10.75 — 10.75		Red			
	11.10 — 11.46		Black		11.10 — 11.46		Black			
12"	12.24 — 12.50		Red		12.24 — 12.50		Red	6"	7	54.5
	12.75 — 12.75		Red		12.75 — 12.75		Red			
	13.20 — 13.56		Black		13.20 — 13.56		Black			

To Order: Locate the gasket range that accommodates your pipe O.D. for both pipe ends. Use the top range of each gasket size to determine the part number. For example: to connect pipe with an O.D. of 6.63 to a pipe with an O.D. of 7.10, the catalog number is FC1-690-720.

- Options:** **SH** Standard coated coupling with Type 304 stainless steel nuts and bolts: add "-SH" to the catalog number.
ESH Epoxy coated coupling with Type 304 stainless steel nuts and bolts: add "-ESH" to the catalog number.
BBN Blue fluorocarbon coating on HSLA nuts and bolts. Add "-BBN" to catalog number.
N NBR (Buna-N) gasket, standard coated coupling and standard alloy bolts. Add "-N" to the catalog number.
Example: FC1-690-720-ESH is an FC1 coupling with epoxy coating and stainless steel nuts and bolts.

Component Parts for Style FC1 Couplings

NOM. PIPE SIZE	GASKET CAT. No.	END RING CAT. No.	CENTER SLEEVE CAT. No.	BOLT AND NUT CAT. No.
2"	FC1G-234-263	FC1-RER-2	FC1-CS-2	FBN-58-65
	FC1G-400	FC1-RER-4		
4"	FC1G-450-480	FC1-RER-4	FC1-CS-4	FBN-58-8
	FC1G-480-510	FC1-BER-4		
	FC1G-600	FC1-RER-6		
6"	FC1G-630	FC1-RER-6	FC1-CS-6	FBN-58-8
	FC1G-663-690	FC1-RER-6		
	FC1G-690-720	FC1-BER-6		
	FC1G-800	FC1-RER-8		
8"	FC1G-816-840	FC1-RER-8	FC1-CS-8	FBN-58-8
	FC1G-863-905	FC1-RER-8		
	FC1G-905-940	FC1-BER-8		
	FC1G-1020-1050	FC1-RER-10		
10"	FC1G-1075	FC1-RER-10	FC1-CS-10	FBN-58-9
	FC1G-1110-1146	FC1-BER-10		
	FC1G-1224-1250	FC1-RER-12		
12"	FC1G-1275	FC1-RER-12	FC1-CS-12	FBN-58-9
	FC1G-1320-1356	FC1-BER-12		

To Order: Order by catalog number from the table.

Caution: Restrain if necessary to provide thrust resistance.
Flexible couplings do not prevent axial pipe movement.

Ford Transition Couplings

Style FC2A



LXI Products meet
ANSI/NSF Standard 61
see page 3



Ford Iron Transition Couplings provide a convenient method of joining two pipes of the same nominal size but with different O.D.s. Gaskets are embossed and End Rings are color coded for easy identification. End Rings are color coded for various pipe sizes per the following chart. The gaskets are identified with the exact O.D. range and the End Ring color with which it is to be used. Generally Red signifies use on steel size PVC, Black for iron pipe and Class 150 A/C, and White/Gray for Class 200 A/C. See the table below for exact ranges. Larger, Fabricated Steel Couplings are detailed in Catalog Section N.

Rated: 250 psi working pressure (sizes 2" - 12")
150 psi working pressure (sizes 14" - 24")

Caution: Restrain if necessary to provide thrust resistance.
Flexible couplings do not prevent axial pipe movement.

NOM. PIPE SIZE	GASKET RANGE		END RING COLOR CODE	BY	GASKET RANGE		END RING COLOR CODE	CENTER SLEEVE LENGTH	NUMBER OF BOLTS	APPROX. WEIGHT LBS
	1ST. HALF CAT. No.	2ND HALF CAT. No.			1ST. HALF CAT. No.	2ND HALF CAT. No.				
2"	2.30 — 2.45	2.45	Black	X	2.30 — 2.45	2.45	Black	4"	2	9
	2.40 — 2.65	2.65	Black		2.40 — 2.65	2.65	Black			
	2.65 — 2.88	2.88	Black		2.65 — 2.88	2.88	Black			
3"	3.13 — 3.13	3.13	Red	X	3.13 — 3.13	3.13	Red	4"	3	14
	3.45 — 3.60	3.60	Red		3.45 — 3.60	3.60	Red			
	3.70 — 3.88	3.88	Black		3.70 — 3.88	3.88	Black			
	3.91 — 4.06	4.06	Black		3.91 — 4.06	4.06	Black			
	4.07 — 4.20	4.20	Black		4.07 — 4.20	4.20	Black			
4"	4.00 — 4.00	4.00	Red	X	4.00 — 4.00	4.00	Red	5"	3	16
	4.50 — 4.50	4.50	Red		4.50 — 4.50	4.50	Red			
	4.80 — 5.14	5.14	Black		4.80 — 5.14	5.14	Black			
	5.15 — 5.57	5.57	White/Gray		5.15 — 5.57	5.57	White/Gray			
6"	6.00 — 6.00	6.00	Red	X	6.00 — 6.00	6.00	Red	5"	4	24
	6.63 — 6.63	6.63	Red		6.63 — 6.63	6.63	Red			
	6.90 — 7.20	7.20	Black		6.90 — 7.20	7.20	Black			
	7.21 — 7.56	7.56	White/Gray		7.21 — 7.56	7.56	White/Gray			
8"	8.00 — 8.00	8.00	Red	X	8.00 — 8.00	8.00	Red	5"	5	34
	8.63 — 8.63	8.63	Red		8.63 — 8.63	8.63	Red			
	9.05 — 9.40	9.40	Black		9.05 — 9.40	9.40	Black			
	9.40 — 9.74	9.74	White/Gray		9.40 — 9.74	9.74	White/Gray			
10"	10.00 — 10.00	10.00	Red	X	10.00 — 10.00	10.00	Red	6"	6	48
	10.75 — 10.75	10.75	Red		10.75 — 10.75	10.75	Red			
	11.10 — 11.40	11.40	Black		11.10 — 11.40	11.40	Black			
	11.42 — 11.77	11.77	Black		11.42 — 11.77	11.77	Black			
	11.77 — 12.12	12.12	White/Gray		11.77 — 12.12	12.12	White/Gray			
12"	12.00 — 12.00	12.00	Black	X	12.00 — 12.00	12.00	Black	6"	7	62
	12.75 — 12.75	12.75	Black		12.75 — 12.75	12.75	Black			
	13.20 — 13.50	13.50	Black		13.20 — 13.50	13.50	Black			
	13.69 — 14.04	14.04	White/Gray		13.69 — 14.04	14.04	White/Gray			
	14.03 — 14.38	14.38	White/Gray		14.03 — 14.38	14.38	White/Gray			
14"	15.30 — 15.70	15.70	Black	X	15.30 — 15.70	15.70	Black	6"	9	83
	16.00 — 16.35	16.35	Red		16.00 — 16.35	16.35	Red			
	16.40 — 16.88	16.88	White/Gray		16.40 — 16.88	16.88	White/Gray			
16"	17.40 — 17.80	17.80	Black	X	17.40 — 17.80	17.80	Black	6"	10	103
	18.45 — 18.97	18.97	White/Gray		18.45 — 18.97	18.97	White/Gray			
	18.90 — 19.20	19.20	White/Gray		18.90 — 19.20	19.20	White/Gray			
18"	19.50 — 20.00	20.00	Black	X	19.50 — 20.00	20.00	Black	7"	11	111
20"	21.60 — 22.06	22.06	Black	X	21.60 — 22.06	22.06	Black	7"	12	125
24"	25.80 — 26.32	26.32	Black	X	25.80 — 26.32	26.32	Black	10"	14	183

To Order: Locate the gasket range that accommodates your pipe O.D. for both ends of pipe. Use the top range of each gasket size to determine the part number. For example: to connect pipe with an O.D. of 6.90 to a pipe with an O.D. of 7.37, the catalog number is FC2A-720-756.

- Options:** **SH** Standard coated coupling with Type 304 stainless steel nuts and bolts: add "-SH" to the catalog number.
ESH Epoxy coated coupling with Type 304 stainless steel nuts and bolts: add "-ESH" to the catalog number.
BBN Blue fluorocarbon coating on HSLA nuts and bolts. Add "-BBN" to catalog number.
N NBR (Buna-N) gasket, standard coated coupling and standard alloy bolts. Add "-N" to the catalog number.

Example for above options: FC2A-690-720-ESH is an FC2A coupling with epoxy coating and stainless steel nuts and bolts.

Gasket for SDR 35 Sewer Pipe: Gaskets are available in following sizes : 4.22", 6.23", 8.40", 10.50" and 12.50". Use these sizes as part of the catalog number.

Ford Transition Coupling Parts

Style FC2A



Component Parts for Style FC2A Couplings

NOM. PIPE SIZE	GASKET CATALOG No.	END RING CATALOG No.	CENTER SLEEVE CATALOG No.	BOLT AND NUT CATALOG No.	BOLT AND NUT SIZE	NUMBER OF BOLTS REQUIRED
2"	FC2AG-230-245	FC2A-BER-2	FC2A-CS-2	FBN-58-65	5/8" x 6-1/2"	2
	FC2AG-240-265	FC2A-BER-2				
	FC2AG-265-288	FC2A-BER-2				
3"	FC2AG-313	FC2A-RER-3	FC2A-CS-3	FBN-58-65	5/8" x 6-1/2"	3
	FC2AG-345-360	FC2A-RER-3				
	FC2AG-370-388	FC2A-BER-3				
	FC2AG-391-406	FC2A-BER-3				
	FC2AG-407-420	FC2A-BER-3				
4"	FC2AG-400	FC2A-RER-4	FC2A-CS-4	FBN-58-8	5/8" x 8"	3
	FC2AG-450	FC2A-RER-4				
	FC2AG-480-514	FC2A-BER-4				
	FC2AG-515-557	FC2A-WER-4				
6"	FC2AG-600	FC2A-RER-6	FC2A-CS-6	FBN-58-8	5/8" x 8"	4
	FC2AG-663	FC2A-RER-6				
	FC2AG-690-720	FC2A-BER-6				
	FC2AG-721-756	FC2A-WER-6				
8"	FC2AG-800	FC2A-RER-8	FC2A-CS-8	FBN-58-8	5/8" x 8"	5
	FC2AG-863	FC2A-RER-8				
	FC2AG-905-940	FC2A-BER-8				
	FC2AG-940-974	FC2A-WER-8				
10"	FC2AG-1000	FC2A-RER-10	FC2A-CS-10	FBN-58-9	5/8" x 9"	6
	FC2AG-1075	FC2A-RER-10				
	FC2AG-1110-1140	FC2A-BER-10				
	FC2AG-1142-1177	FC2A-BER-10				
12"	FC2AG-1177-1212	FC2A-WER-10	FC2A-CS-12	FBN-58-9	5/8" x 9"	7
	FC2AG-1200	FC2A-BER-12				
	FC2AG-1275	FC2A-BER-12				
	FC2AG-1320-1350	FC2A-BER-12				
	FC2AG-1369-1404	FC2A-WER-12				
14"	FC2AG-1403-1438	FC2A-WER-12	FC2A-CS-14	FBN-58-105	5/8"x10-1/2"	9
	FC2AG-1530-1570	FC2A-BER-14				
	FC2AG-1600-1635	FC2A-RER-14				
16"	FC2AG-1640-1688	FC2A-WER-14	FC2A-CS-16	FBN-58-105	5/8"x10-1/2"	10
	FC2AG-1740-1780	FC2A-BER-16				
	FC2AG-1845-1897	FC2A-WER-16				
18"	FC2AG-1890-1920	FC2A-WER-16	FC2A-CS-18	FBN-58-105	5/8"x10-1/2"	11
	FC2AG-1950-2000	FC2A-BER-18				
20"	FC2AG-2160-2206	FC2A-BER-20	FC2A-CS-20	FBN-58-105	5/8"x10-1/2"	12
24"	FC2AG-2580-2632	FC2A-BER-24	FC2A-CS-24	FBN-58-135	5/8"x13-1/2"	14

To Order: Specify desired quantity and order using catalog number.

Ford Ultra-Flex Wide Range Couplings

Style FC2W

Ford Ultra-Flex wide range couplings offer convenience, reliability, and inventory reduction. The Ultra-Flex can join virtually any two pipes within a nominal size and is rated for 250 psi working water pressure. The stab-in design allows quicker installation and the standard fusion bonded epoxy coating provides corrosion protection. The standard NBR (Buna-N) gaskets are lubricated at the factory. No on site lubrication is required. The unique curved gaskets seal on the pipe with fewer turns of the wrench. This allows the installer to use a standard deep-well socket, even when installing on pipes at the low end of the listed range. See the table below for exact ranges.

Benefits:

- Stab-in installation. No disassembly required.
- Long standard sleeve.
- Curved gasket allows for quicker installation.
- 250 psi rated working pressure.

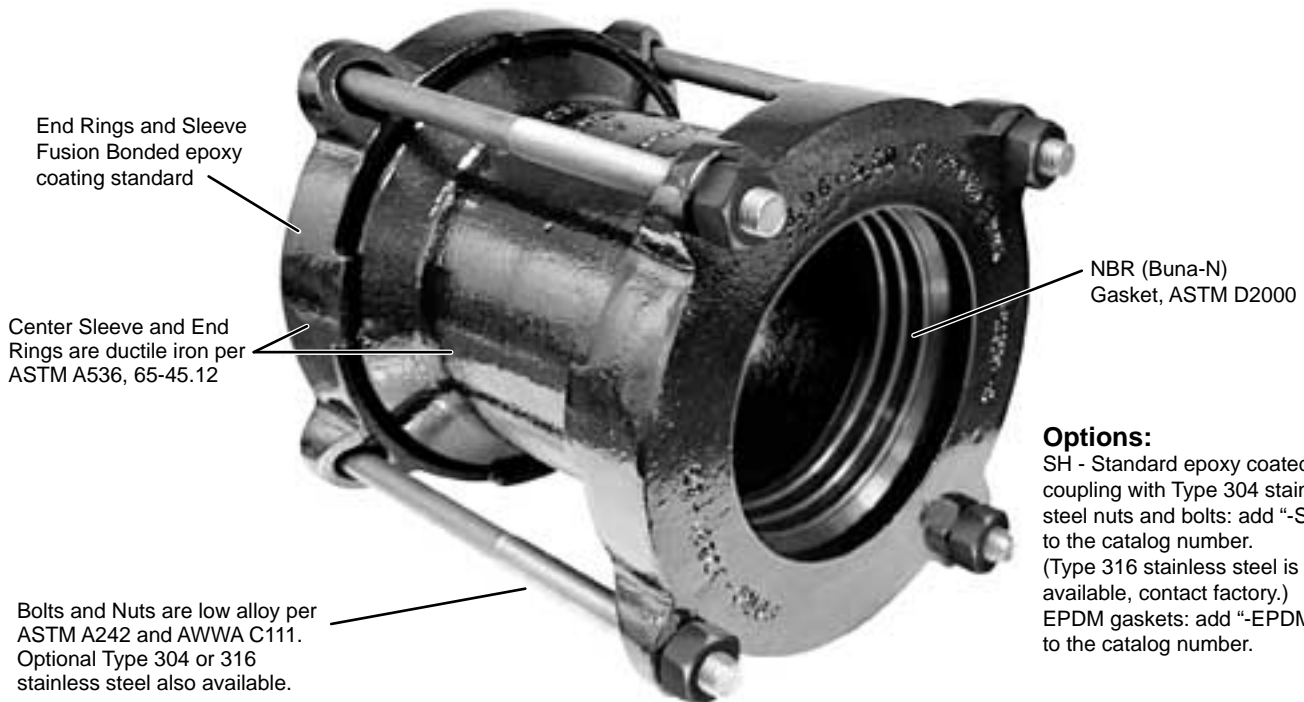

Options:

SH - Standard epoxy coated coupling with Type 304 stainless steel nuts and bolts: add "-SH" to the catalog number. (Type 316 stainless steel is available, contact factory.)
 EPDM gaskets: add "-EPDM" to the catalog number.

Caution: Restrain if necessary to provide thrust resistance.
 Flexible couplings do not prevent axial pipe movement.

NOMINAL PIPE SIZE	PIPE OD RANGE*		CATALOG NUMBER	NUMBER OF BOLTS	BOLT DIAMETER	SLEEVE LENGTH	APPROX. WEIGHT LBS.
	INCHES	MM					
4"	3.96 - 5.60	100.5 - 142.2	FC2W-4	4	5/8"	7"	35
6"	6.23 - 7.60	158.2 - 193.0	FC2W-6	4	5/8"	7"	44
8"	8.40 - 9.75	213.3 - 247.6	FC2W-8	4	5/8"	7"	52
10"	10.75 - 12.12	273.0 - 307.8	FC2W-10	6	5/8"	9"	76
12"	12.75 - 14.38	323.8 - 365.25	FC2W-12	6	5/8"	9"	97

* Pipes smaller than the published range may be joined using the FC2W coupling at a reduced pressure rating. Contact Ford Meter Box for details.

- Options:** SH Type 304 stainless steel nuts and bolts: add "-SH" to the catalog number.
 EPDM EPDM gaskets: add "-EPDM" to the catalog number.
 BBN Blue fluorocarbon coating on HSLA nuts and bolts. Add "-BBN" to catalog number.
 EC End Cap (see page M-13)

(Contact factory for Type 316 stainless steel nuts and bolts.)

Ford Ultra-Flex Wide Range Coupling Parts

Style FC2W

Component Parts for FC2W Couplings

NOMINAL PIPE SIZE	GASKET CATALOG NUMBER	END RING CATALOG NUMBER	CENTER SLEEVE CATALOG NUMBER	BOLT AND NUT CATALOG NUMBER	BOLT AND NUT SIZE	NUMBER OF BOLTS REQUIRED
4"	FC2WG-4	FC2W-ER-4	FC2W-CS-4	FBN-58-1125	5/8"x11-1/4"	4
6"	FC2WG-6	FC2W-ER-6	FC2W-CS-6	FBN-58-1125	5/8"x11-1/4"	4
8"	FC2WG-8	FC2W-ER-8	FC2W-CS-8	FBN-58-1125	5/8"x11-1/4"	4
10"	FC2WG-10	FC2W-ER-10	FC2W-CS-10	FBN-58-135	5/8"x13-1/2"	6
12"	FC2WG-12	FC2W-ER-12	FC2W-CS-12	FBN-58-135	5/8"x13-1/2"	6

Ford Ultra-Flex Long Sleeve Wide Range Couplings

Style FC2W-12" Long



The long sleeve version of the Ford FC2W Ultra-Flex offers the same advantages as the standard FC2W with the added versatility of a 12-inch long center sleeve.

Rating: 250 psi
working water pressure

NOMINAL PIPE SIZE	PIPE OD RANGE		CATALOG NUMBER	NUMBER OF BOLTS	BOLT DIAMETER	SLEEVE LENGTH	APPROX. WEIGHT LBS.
	INCHES	MM					
4"	3.96 - 5.60	100.5 - 142.2	FC2W-4-L12	4	5/8"	12"	45
6"	6.23 - 7.60	158.2 - 193.0	FC2W-6-L12	4	5/8"	12"	56
8"	8.40 - 9.75	213.3 - 247.6	FC2W-8-L12	4	5/8"	12"	68
10"	10.75 - 12.12	273.0 - 307.8	FC2W-10-L12	6	5/8"	12"	90
12"	12.75 - 14.38	323.8 - 365.25	FC2W-12-L12	6	5/8"	12"	109

Component Parts for FC2W-L12 Couplings

NOMINAL PIPE SIZE	GASKET CATALOG NUMBER	END RING CATALOG NUMBER	CENTER SLEEVE CATALOG NUMBER	BOLT AND NUT CATALOG NUMBER	BOLT AND NUT SIZE	NUMBER OF BOLTS REQUIRED
4"	FC2WG-4	FC2W-ER-4	FC2W-CS-4-L12	FBN-58-165	5/8"x16-1/2"	4
6"	FC2WG-6	FC2W-ER-6	FC2W-CS-6-L12	FBN-58-165	5/8"x16-1/2"	4
8"	FC2WG-8	FC2W-ER-8	FC2W-CS-8-L12	FBN-58-165	5/8"x16-1/2"	4
10"	FC2WG-10	FC2W-ER-10	FC2W-CS-10-L12	FBN-58-165	5/8"x16-1/2"	6
12"	FC2WG-12	FC2W-ER-12	FC2W-CS-12-L12	FBN-58-165	5/8"x16-1/2"	6

* Pipes smaller than the published range may be joined using the FC2W coupling at a reduced pressure rating. Contact Ford Meter Box for details.

- Options:** **SH** Type 304 stainless steel nuts and bolts: add "-SH" to the catalog number.
EPDM EPDM gaskets: add "-EPDM" to the catalog number.
BBN Blue fluorocarbon coating on HSLA nuts and bolts. Add "-BBN" to catalog number.
EC End Cap (see page M-13)

(Contact factory for Type 316 stainless steel nuts and bolts.)

Ford Reducing Coupling

Style FRC



LXI Products meet
ANSI/NSF Standard 61
see page 3



Ford Reducing Couplings are designed to connect different size water main pipes. Maximum pipe differential is one nominal pipe size. Material specifications for Style FRC Reducing Couplings are the same as those for Styles FC1 and FC2A Couplings. See page 4 for details.

Larger, Fabricated Steel Reducing Couplings are detailed in Catalog Section N.

NOM. PIPE SIZE	GASKET RANGE		END RING COLOR CODE	BY	GASKET RANGE		END RING COLOR CODE	NUMBER OF BOLTS	APPROX. WEIGHT LBS
	1ST. HALF CAT. No.				2ND HALF CAT. No.				
4"x3"	3.95	4.05	Red	X	3.45	3.60	Red	4	23
	4.45	4.60	Red		3.70	3.88	Black		
	4.80	5.00	Black		3.91	4.06	Black		
	4.92	5.16	Black		4.07	4.20	White/Gray		
	5.17	5.32	White/Gray		-	-	-		
6"x4"	5.95	6.05	Red	X	3.95	4.05	Red	5	37
	6.54	6.76	Red		4.45	4.60	Red		
	6.91	7.12	Black		4.70	4.91	Black		
	7.17	7.37	Black		4.92	5.16	Black		
	7.37	7.60	White/Gray		5.17	5.32	White/Gray		

To order: Locate the gasket range that accommodates your pipe O.D. for both types of pipe. Use the top range of each gasket size to identify the part number. For example: to connect pipe with an O.D. of 6.63 to a pipe with an O.D. of 4.50, the catalog number is FRC-676-460.

Caution: Restrain if necessary to provide thrust resistance. Flexible couplings do not prevent axial pipe movement.

Ford Insulating Boots

Style FIB

Ford Insulating Boots are used to provide a break in electrical conductivity between metallic pipes in order to control corrosion. The 7" long rubber boot slides over the end of the pipe and prevents contact with adjoining pipe. The FIB adds .25" to the outside diameter of the pipe and this is important to consider when ordering accompanying fittings.

Material Specifications: NBR (Buna-N) Rubber per ASTM D2000.



The Ford FIB

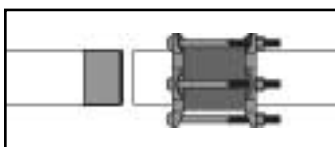

Place the FIB on one pipe end and the coupling on the adjoining pipe

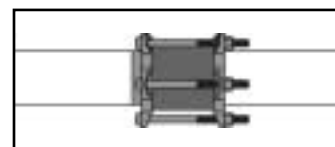

Complete the installation according to the coupling instructions.

NOM. PIPE SIZE	PIPE O.D.	CATALOG NUMBER	APPROX. Wt. LBS.
4"	4.80	FIB-480	.7
6"	6.90	FIB-690	1.0
8"	9.05	FIB-905	1.3
10"	11.10	FIB-1110	1.6
12"	13.20	FIB-1320	1.9

Note: Additional sizes built to the same specification are available upon request.



LXI Products meet
ANSI/NSF Standard 61
see page 3

Ford Flanged Coupling Adapters

Style FFCA



* Rated Working Pressure: 175 PSI

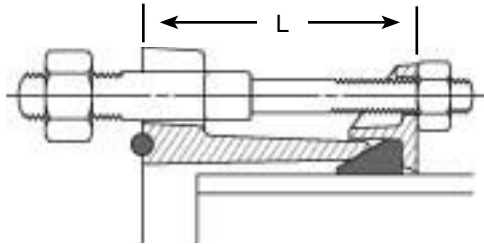

Ford Flanged Coupling Adapters are used to join plain end pipe to flanged fittings. The FFCA is designed without pipe stops and can slide completely over the pipe to allow for clearance. The adapter is furnished with HSLA tee-head bolts and/or ductile iron cross bolts. The flange has a built-in O-ring gasket. Larger, Fabricated Steel Flanged Coupling Adapters are detailed in Catalog Section N.

Material Specifications:

1. **Body** - Ductile Iron per ASTM A536 65-45-12.
2. **End Rings** - Ductile Iron per ASTM A536 65-45-12.
3. **Coupling Gasket** - SBR per ASTM D2000.
4. **Cross Bolts, T-Bolts & Nuts** - High Strength Low Alloy Steel per AWWA C-111 or Ductile Iron per ASTM A536, 65-45-12. Optional blue fluorocarbon coating.
5. **Finish** - Shop coat. Optional epoxy coating is available upon request.
6. **Flange** - Drilling per ANSI/AWWA C110/A21.10, AWWA C207 and per ANSI B16.1 Class 125.
7. **Flange O-Ring** - NBR (Buna-N).
8. **Optional Anchor Studs** - C1141 cold rolled steel or Type 416 stainless steel.

***Caution:** Restrain if necessary to provide thrust resistance. Flexible couplings do not prevent axial pipe movement. See Anchor Stud options below.

NOMINAL PIPE SIZE	PIPE O.D. RANGE	CATALOG NUMBER	END RING COLOR CODE	APPROX. ASSEMBLED LENGTH (L)	APPROX. WEIGHT LBS.	OPTIONAL ANCHOR STUDS	No. AND SIZE OF	
							CROSS BOLTS	T-BOLTS
							CATALOG NUMBER	CATALOG NUMBER
3"	3.45-3.60	FFCA-360	Red	3-7/8"	18	2	4 5/8" x 5/8" FCBN-58-58	N/A
	3.70-3.88	FFCA-388	Black		18			
	3.91-4.06	FFCA-406	Black		18			
	4.07-4.20	FFCA-420	White/Gray		18			
4"	4.45-4.60	FFCA-460	Red	3-1/2"	22	2	4 5/8" x 5/8" FCBN-58-58	4 5/8" FTBN-58-3
	4.70-4.91	FFCA-491	Black		22			
	4.92-5.16	FFCA-516	Black		22			
	5.17-5.32	FFCA-532	White/Gray		22			
6"	6.54-6.76	FFCA-676	Red	4-1/8"	34	2	4 3/4" x 5/8" FCBN-34-58	4 3/4" FTBN-34-35
	6.81-7.12	FFCA-712	Black		34			
	7.17-7.37	FFCA-737	Black		34			
	7.37-7.60	FFCA-760	White/Gray		34			
8"	8.50-8.75	FFCA-875	Red	4-3/16"	45	4	8 3/4" x 5/8" FCBN-34-58	N/A
	8.76-9.17	FFCA-917	Black		45			
	9.22-9.50	FFCA-950	Black		45			
	9.49-9.79	FFCA-979	White/Gray		45			
10"	10.69-10.85	FFCA-1085	Red	4-13/16"	55	4	12 7/8" x 5/8" FCBN-78-58	N/A
	11.04-11.40	FFCA-1140	Black		55			
12"	12.72-12.84	FFCA-1284	Red	4-3/4"	63	4	12 7/8" x 5/8" FCBN-78-58	N/A
	13.14-13.56	FFCA-1356	Black		63			

Note: End Rings for FFCA's are not interchangeable with the balance of the Ford Coupling System. For fabricated or larger flange coupling adapters, see Catalog Section N.

Optional Anchor Studs (C1141 cold rolled steel or Type 416 stainless steel)

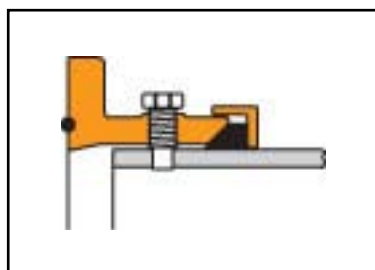

(Use of Anchor Studs requires field drilling of pipe.)

Optional Anchor Studs provide restraint against axial pipe movement. For use on ductile iron or steel pipe. See table above for optional stud quantities.

Optional Anchor Studs: For two studs add "-AS2" to the catalog number.

For four studs add "-AS4" to the catalog number.

Example: FFCA-712-AS2

Ford Cut-In Couplings

Style FRR



LXI Products meet
ANSI/NSF Standard 61
see page 3



Designed specifically for Cut-In applications

Ford Style FRR Cut-in Couplings allow the joining of pipe where the gap between the pipe ends is greater than normal. This fitting is commonly used to replace leaking couplings that require removal.

The three-piece steel sleeve allows disassembly for installation through the space between two existing stationary pipe ends.

Material Specifications:

1. **Sleeve** - Ductile Iron per ASTM A536, 65-45-12.
2. **Repair Ring** - Ductile Iron per ASTM A536 or steel per ASTM A36.
3. **End Rings** - Ductile Iron per ASTM A536, 65-45-12.
4. **Gaskets** - NBR (Buna-N) per ASTM D2000.
5. **Bolts** - High strength low alloy per ASTM A242 and AWWA C111.
6. **Finish** - Shop coat. Optional epoxy coating is available upon request.

NOM. PIPE SIZE	PIPE O.D. RANGE	CATALOG NUMBER	APPROX. WT. LBS.	BOLT AND NUT CATALOG NUMBER	BOLT AND NUT SIZE	NUMBER OF BOLTS REQUIRED
4"	4.80-5.14	FRR-514	38	FBN-58-155	5/8"x15-1/2"	3
	5.15-5.57	FRR-557	38			
6"	6.90-7.20	FRR-720	61	FBN-58-155	5/8"x15-1/2"	4
	7.21-7.56	FRR-756	61			
8"	9.05-9.40	FRR-940	82	FBN-58-155	5/8"x15-1/2"	5
	9.40-9.74	FRR-974	82			
10"	11.10-11.40	FRR-1140	105	FBN-58-175	5/8"x17-1/2"	6
	11.42-11.77	FRR-1177	105			
	11.77-12.12	FRR-1212	105			
12"	13.20-13.50	FRR-1350	135	FBN-58-175	5/8"x17-1/2"	7
	13.69-14.04	FRR-1404	135			
	14.03-14.38	FRR-1438	135			

Note: A repair ring can be manufactured for any size 4" through 12" FC2A listed on page 6.

Caution: Restrain if necessary to provide thrust resistance.
Flexible couplings do not prevent axial pipe movement.

Options: SH Standard coated coupling with Type 304 stainless steel nuts and bolts: add "-SH" to the catalog number.

ESH Epoxy coated coupling with Type 304 stainless steel nuts and bolts: add "-ESH" to the catalog number.

BBN Blue fluorocarbon coating on HSLA nuts and bolts. Add "-BBN" to catalog number.

Example for above options: FRR-720-ESH is an FRR coupling with epoxy coating and stainless steel nuts and bolts.



LXI Products meet
ANSI/NSF Standard 61
see page 3

Ford End Cap Couplings

Style **FEC**



The Ford End Cap Coupling, Style FEC, is provided with 2" female iron pipe threaded boss (less the pipe plug). The boss is located in the center as standard, optional locations are available. Blind end caps may be furnished upon request. For Blind End Cap add "-BEC" to the catalog number. Example: FEC-863-BEC.

Material Specifications:

- Sleeve** - Ductile Iron per ASTM A536, 65-45-12.
- End Rings** - Ductile Iron per ASTM A536, 65-45-12.
- Gaskets** - NBR (Buna-N) per ASTM D2000.
- End Cap** - Steel with 2" female iron pipe threaded boss.
- Bolts** - High strength low alloy per ASTM A242 and AWWA C111.
- Finish** - Shop coat. Optional epoxy coating is available upon request.

NOM. PIPE SIZE	PIPE O.D. RANGE	CATALOG NUMBER	APPROX. WT. LBS.	END CAP ONLY (INCLUDES GASKET)		NUMBER OF BOLTS REQUIRED
				FC1 COUPLING	FC2A COUPLING	
4"	4.00	FEC-400	21	FEC1-4	FEC2-4	3
	4.50	FEC-450				
	4.80-5.14	FEC-514				
	5.15-5.57	FEC-557				
6"	6.00	FEC-600	31	FEC1-6	FEC2-6	4
	6.63	FEC-663				
	6.90-7.20	FEC-720				
	7.21-7.56	FEC-756				
8"	8.00	FEC-800	41	FEC1-8	FEC2-8	5
	8.63	FEC-863				
	9.05-9.40	FEC-940				
	9.40-9.74	FEC-974				
10"	11.10-11.40	FEC-1140	55	FEC1-10	FEC2-10	6
	11.77-12.12	FEC-1212				
12"	13.20-13.50	FEC-1350	66	FEC1-12	FEC2-12	7

NOTE: Larger fabricated end cap couplings are listed in Section "N".

Caution: Restrain if necessary to provide thrust resistance. Flexible couplings do not prevent axial pipe movement.

- Options:**
- SH** Standard coated coupling with Type 304 stainless steel nuts and bolts: add "-SH" to the catalog number.
 - ESH** Epoxy coated coupling with Type 304 stainless steel nuts and bolts: add "-ESH" to the catalog number.
 - BBN** Blue fluorocarbon coating on HSLA nuts and bolts. Add "-BBN" to catalog number.
 - BEC** Blind End Cap, no female iron pipe threads. Add "-BEC" to the catalog number.

Example for above options: FEC-720-ESH is an FEC coupling with epoxy coating and stainless steel nuts and bolts.

Ford End Cap for Ultra-Flex Wide Range Couplings

Style **FC2W-EC**



The Ford End Cap Coupling, Style FC2W-EC, is provided with 2" female iron pipe threaded boss (less the pipe plug). The boss is located in the center as standard, optional locations are available on 10" and 12" end caps.

Material Specifications:

- Sleeve** - Ductile Iron per ASTM A536, 65-45-12.
- End Rings** - Ductile Iron per ASTM A536, 65-45-12.
- Gaskets** - NBR (Buna-N) per ASTM D2000.
- End Cap** - Ductile Iron per ASTM A536, 65-45-12 or Steel per ASTM A36.
- Bolts** - High strength low alloy per ASTM A242 and AWWA C111.
- Finish** - Sleeve and end rings are epoxy coated. 4", 6" and 8" E-Coat End Caps
10" and 12" epoxy coated End Caps

NOM. PIPE SIZE	PIPE O.D. RANGE		CATALOG NUMBER	APPROX. WT. LBS.	END CAP ONLY	END CAP WT. LBS.
	INCHES	MM				
4"	3.96-5.60	100.5 - 142.2	FC2W-4-EC	44	FECW-4	9
6"	6.23-7.60	158.2 - 193.0	FC2W-6-EC	57	FECW-6	13
8"	8.40-9.75	213.3 - 247.6	FC2W-8-EC	75	FECW-8	23
10"	10.77-12.12	273.0 - 307.8	FC2W-10-EC	138	FECW-10	62
12"	12.75-14.38	323.8 - 365.25	FC2W-12-EC	178	FECW-12	80

Ford Ultra-Flex Long Sleeve Wide Range Couplings

Style **FC2W-EC (12" Long)**

NOM. PIPE SIZE	PIPE OD RANGE		CATALOG NUMBER	SLEEVE LENGTH	APPROX. WT. LBS.	END CAP ONLY	END CAP WT. LBS.
	INCHES	MM					
4"	3.96 - 5.60	100.5 - 142.2	FC2W-4-L12-EC	12"	54	FECW-4	9
6"	6.23 - 7.60	158.2 - 193.0	FC2W-6-L12-EC	12"	69	FECW-6	13
8"	8.40 - 9.75	213.3 - 247.6	FC2W-8-L12-EC	12"	91	FECW-8	23
10"	10.75 - 12.12	273.0 - 307.8	FC2W-10-L12-EC	12"	152	FECW-10	62
12"	12.75 - 14.38	323.8 - 365.25	FC2W-12-L12-EC	12"	189	FECW-12	80

O.D. Chart

Nom. Pipe Size	PVC (Steel Size)	PVC C900	CAST IRON			ASBESTOS-CEMENT			STEEL	
	O.D.	O.D.	Classes		O.D.	Class	Machined End O.D.	Rough Barrel O.D. Min — Max	Type	O.D.
			Pit	Spun						
1/2"	.84								STD.	.84
3/4"	1.05								STD.	1.05
1"	1.32								STD.	1.32
1-1/4"	1.66								STD.	1.66
1-1/2"	1.90								STD.	1.90
2"	2.38	2.50			2.50				STD.	2.38
2-1/2"	2.88								STD.	2.88
3"	3.50		A B, C, D	50 - 350	3.80	100	3.74	4.00	O.D.	3.00
					3.96	150	3.84	4.10	STD.	3.50
						200	3.84	4.29		
4"	4.50	4.80	A B, C, D	50 - 350	4.80	100	4.64	4.79 — 5.14	O.D.	4.00
					5.00	150	4.81	4.97 — 5.27	STD.	4.50
						200	4.81	5.22 — 5.57		
6"	6.63	6.90	A B, C, D E, F	50 - 350	6.90	100	6.91	7.05 — 7.40	O.D.	6.00
					7.10	150	6.91	7.07 — 7.37	STD.	6.63
					7.22	200	6.91	7.26 — 7.56		
8"	8.63	9.05	A, B C, D E, F	50 - 300	9.05	100	9.11	9.22 — 9.57	O.D.	8.00
				350	9.30	150	9.11	9.27 — 9.57	STD.	8.63
					9.42	200	9.11	9.39 — 9.74		
10"	10.75	11.10	A, B C, D E, F	50 - 200	11.10	100	11.24	11.42 — 11.77	O.D.	10.00
				250 - 350	11.40	150	11.66	11.82 — 12.12	STD.	10.75
					11.60	200	11.66	11.77 — 12.12		
12"	12.75	13.20	A, B C, D E, F	50 - 200	13.20	100	13.44	13.69 — 14.04	O.D.	12.00
				250 - 350	13.50	150	13.92	14.08 — 14.38	STD.	12.75
					13.76	200	13.92	14.03 — 14.38		
14"	14.00	15.30	A, B C, D E, F	50 - 100	15.30	100	15.07	15.40 — 15.80	O.D.	14.00
				150 - 300	15.65	150	16.22	16.38 — 16.73		
					15.98	200	16.22	16.48 — 16.88		
16"	16.00	17.40	A, B C, D E, F	50 - 100	17.40	100	17.14	17.54 — 17.94	O.D.	16.00
				150 - 300	17.80	150	18.46	18.62 — 18.97		
					18.16	200	18.46	18.79 — 19.19		
18"	18.00	19.50	A, B C, D	50 - 100	19.50	100	19.90	20.44	STD.	18.00
				150 - 250	19.92	150	20.94	21.20		
20"	20.00	21.60	A, B C, D	50 - 100	21.60	100	22.12	22.50	STD.	20.00
				150 - 250	22.06	150	23.28	23.54		
24"	24.00	25.80	A, B C, D	50 - 100	25.80	100	26.48	27.17	STD.	24.00
				150 - 250	26.32	150	27.96	28.22		

NOTE: Due to variations in outside diameters and specifications, dimensions listed are approximate. For this reason, determine the actual pipe O.D. before ordering Ford Pipe Coupling Products.

FC2W Ultra-Flex Installation Instructions

1. Measure the outside diameter of each pipe end to be joined to ensure they are within the coupling range.
2. Thoroughly clean each pipe end to a smooth, bare sealing surface.
3. Stab each pipe end into the Ultra-Flex coupling. For ease of installation, it may be necessary to loosen the nuts when assembling on larger O.D. pipes. Disassembly of the coupling is not required. **NOTE: Do not lubricate the pipe OD or the gasket. If the coupling is disassembled, lubricate only the contoured lip on each end of the coupling sleeve prior to reassembly.**
4. Center the coupling between the two pipe ends. The optimum pipe end gap for the Ultra-Flex coupling is less than 1".
5. Evenly tighten bolts in an alternating sequence being certain that end rings remain parallel to one another. Tighten bolts to 50 ft-lb.
6. Restrain if necessary, test and recheck bolt torque before backfilling. If a leak develops during testing, recheck bolt torque. Be advised that extreme torque can over stress coupling components.

Installation Instructions

Ford Flexible Couplings (Except FC2W Ultra-Flex Coupling)

1. Measure pipe O.D. to ensure it is within the coupling range.
2. Thoroughly clean each pipe end to a smooth, bare surface sufficiently longer than coupling length.
3. Slide the proper end ring onto each pipe end.
4. Lubricate the pipe ends and the gaskets before assembly to assist proper gasket seating. Use a non-petroleum based lubricant (suitable for potable water). In cold conditions, warm gasket to approximately 65 degrees before installation to improve elasticity.
5. Place the proper gasket on each pipe end with the beveled edge facing the pipe end.
6. Slide center sleeve onto one pipe end, then center the sleeve over the pipe ends.

Sleeve Length	5"	6"	7"	10"
Optimum Pipe End Gap	.50"	.50"	1.00"	1.00"

7. **Extremely Important: Block and shim pipe ends and coupling as needed to ensure that the coupling remains at an equal distance from the pipe circumference.**

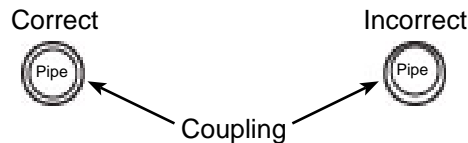

8. Push gaskets (by hand) into center sleeve evenly. Position end rings against the gaskets. Insert and tighten all bolts finger tight. Evenly tighten bolts in an alternating sequence being certain that end rings remain parallel to one another.

1/2" Bolts = 40 - 50 ft. lbs.

5/8" Bolts = 60 - 70 ft. lbs.

9. Restrain if necessary, test and recheck bolt torque before backfilling. If a leak develops during testing tighten bolts to stop leak; however, extreme torque can over stress coupling components.

CAUTION

- Flexible couplings do not restrain axial movement of pipe.
- Flexible couplings are designed to float on pipe ends and are not designed to support the pipe.

Section M

Ford Bolted Flex Couplings

Warranty

All merchandise is warranted to be free from defects in material and factory workmanship. We will provide free of charge new products in equal quantities for any that prove defective within one year from date of shipment from our factory. Manufacturer shall not be liable for any loss, damage, or injury, direct or consequential, arising out of the use of or the inability to use the product. Before using, user shall determine the suitability of product for his intended use and user assumes all risk and liability whatever in connection therewith. No claims for labor or consequential damage will be allowed. The foregoing may not be changed except by agreement signed by an officer of the manufacturer.

Please Note:

Consult the Ford Meter Box Company, Inc. website (www.fordmeterbox.com) for the most recent catalog information. The Ford Meter Box Company considers the information in this catalog to be correct at the time of publication. Items and option availability, including specifications, are subject to change without notice. Please verify that your product information is current.



The Ford Meter Box Co., Inc. 775 Manchester Avenue, P.O. Box 443, Wabash, Indiana, USA 46992-0443
Telephone: 260-563-3171 FAX: 800-826-3487 Overseas FAX: 260-563-0167 <http://www.fordmeterbox.com>