

**GENERAL**

The Badger® M-Series® mag meter model M-2000 detector is the result of years of research and field use in electromagnetic flow meters. Based on Faraday's law of induction, these meters can measure almost any liquid, slurry or paste that has minimum electrical conductivity.

Designed, developed and manufactured under strict quality standards, the M-Series meter features sophisticated, processor-based signal conversion with accuracies of  $\pm 0.25$  percent. The wide selection of liner and electrode materials helps ensure maximum compatibility and minimum maintenance over a long operating period.

**OPERATION**

The flow meter is a stainless steel tube lined with a nonconductive material. Outside the tube, two DC powered electromagnets are positioned diametrically opposing each other. Perpendicular to these coils, two electrodes are inserted into the flow tube. Energized coils create a magnetic field across the whole diameter of the pipe.

As a conductive fluid flows through the magnetic field, a voltage is induced across the electrodes. This voltage is proportional to the average flow velocity of the fluid and is measured by the two electrodes. This induced voltage is then amplified and processed digitally by the converter to produce an accurate analog or digital signal. The signal can then be used to indicate flow rate and totalization or to communicate to remote sensors and controllers.

This technology provides many advantages. With no parts in the flow stream, there is no pressure loss. Also, accuracy is not affected by temperature, pressure, viscosity, density or flow profile. Finally, with no moving parts, there is practically no maintenance required.

**APPLICATION**

Because of its inherent advantages over other more conventional technologies, this meter can be used in the majority of industrial flow applications. Whether the fluid is water or highly corrosive, very viscous, contains a moderate amount of solids or requires special handling, this meter can accurately measure fluid flow. Today, magnetic meters are successfully used in industries including food and beverage, pharmaceutical, water and wastewater, and chemical.

**M-2000 Detector****FEATURES**

- $\pm 0.25$  percent accuracy independent of fluid viscosity, density and temperature
- Unaffected by most solids contained in fluids
- Pulsed DC magnetic field for zero point stability
- No pressure loss for low operational costs
- Corrosion resistant liners for long life
- Calibrated in state-of-the art facilities
- Integral and remote signal converter availability
- Optional grounding rings or grounding electrode
- Measurement largely independent of flow profile
- NSF listed

**ELECTRODES**

When looking from the end of the meter into the inside bore, the two measuring electrodes are positioned at three o'clock and nine o'clock. M-2000 mag meters have an "empty pipe detection" feature. This is accomplished with a third electrode positioned in the meter between twelve o'clock and one o'clock. If this electrode is not covered by fluid for a minimum five-second duration, the meter will display an "empty pipe detection" condition, send out an error message if desired, and stop measuring to maintain accuracy. When the electrode again becomes covered with fluid, the error message will disappear and the meter will continue measuring.

As an option to using grounding rings, a grounding electrode (fourth electrode) can be built into the meter during manufacturing to assure proper grounding. The position of this electrode is at five o'clock.



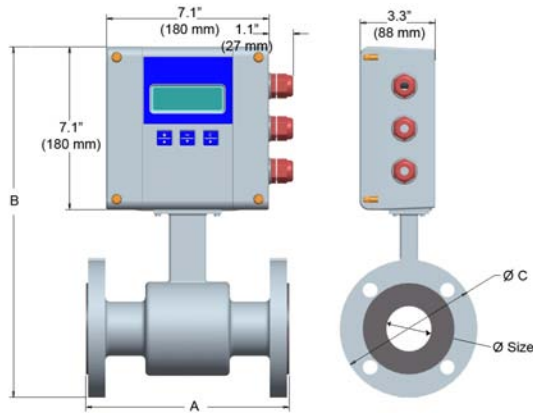

Meter with M-2000 Amplifier

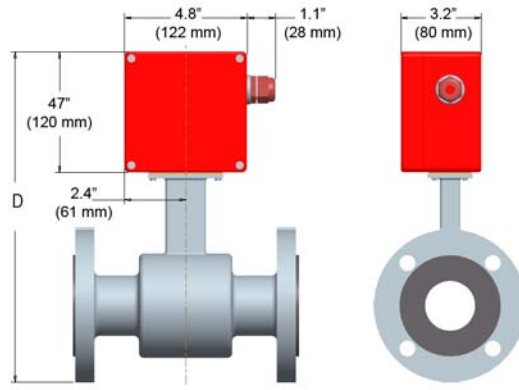

Meter with junction box for remote M-2000 Amplifier

Size	A		B		C		D		Est. Weight with M-2000		Flow Range				
	inch	mm	inch	mm	inch	mm	inch	mm	Lbs	Kg	LPM		GPM		
											Min	Max	Min	Max	
1/4	6	6.7	170	14.0	356	3.5	89	11.4	288	10	4.5	0.063	20	0.02	5
5/16	8	6.7	170	14.0	356	3.5	89	11.4	288	10	4.5	0.114	34	0.03	9
3/8	10	6.7	170	14.0	356	3.5	89	11.4	288	10	4.5	0.177	53	0.05	14
1/2	15	6.7	170	14.0	356	3.5	89	11.4	288	10	4.5	0.416	125	0.11	33
3/4	20	6.7	170	14.2	361	3.9	99	11.5	293	13	5.5	0.75	225	0.2	59
1	25	8.9	225	14.4	366	4.3	108	11.7	298	18	8.0	1.20	350	0.3	93
1 1/4	32	8.9	225	15.2	386	4.6	117	12.5	318	20	9.0	2.00	575	0.5	152
1 1/2	40	8.9	225	15.4	390	5.0	127	12.7	322	21	9.5	3.00	900	0.8	239
2	50	8.9	225	15.9	403	6.0	152	13.2	335	26	11.5	4.70	1400	1	373
2 1/2	65	11.0	280	17.1	434	7.0	178	14.4	366	52	23.5	8	2400	2	631
3	80	11.0	280	17.3	440	7.5	191	14.7	372	54	24.5	12	3600	3	956
4	100	11.0	280	18.4	466	9.0	229	15.7	398	56	25.5	19	5600	5	1493
5	125	15.8	400	19.6	498	10.0	254	16.9	430	58	26.0	30	8800	8	2334
6	150	15.8	400	20.6	524	11.0	279	17.9	456	60	27.0	40	12700	11	3361
8	200	15.8	400	22.5	572	13.5	343	20.4	518	86	39.0	75	22600	20	5975
10	250	19.7	500	26.8	681	16.0	406	24.1	613	178	81.0	120	35300	30	9336
12	300	19.7	500	28.9	734	19.0	483	26.2	666	207	94.0	170	50800	45	13444
14	350	19.7	500	30.8	782	21.0	533	28.2	716	258	117	230	69200	60	18299
16	400	23.6	590	33.7	856	23.5	597	31.0	788	306	139	300	90400	80	23901
18	450	23.6	590	35.0	890	25.0	635	32.4	822	400	181	380	114000	100	30250
20	500	23.6	590	38.2	969	27.5	699	35.5	901	493	224	470	140000	125	37346
22	550	23.6	590	39.6	1005	29.5	749	36.9	937	523	237	570	170000	150	45188
24	600	23.6	590	42.2	1071	32.0	813	39.5	1003	552	251	680	200000	180	53778
28	700	23.6	590	46.2	1173	36.5	927	44.0	1118	648	294	920	275000	240	73100
30	750	31.5	800	48.3	1228	39.0	984	45.7	1161	702	319	1060	315000	280	84000
32	800	31.5	800	52.2	1325	41.4	1015	49.5	1257	768	349	1200	361000	320	95600
36	900	31.5	800	55.3	1405	46.0	1168	54.1	1374	848	385	1500	457000	400	121000
40	1000	31.5	800	60.0	1525	50.2	1230	57.4	1457	922	419	1900	565000	500	149300
42	1050	36.0	914	66.0	1675	53.0	1346	63.4	1610	1198	499	2100	620000	550	164600
48	1200	39.4	1000	69.9	1775	59.4	1455	67.2	1707	1208	549	2700	814000	720	215100
54	1400	39.4	1000	78.5	1995	68.4	1675	75.9	1927	1362	619	3700	1100000	980	292700

**SPECIFICATIONS - Detector**

**Flow Range:** 0.1 - 39.4 fps (0.03-12 m/s)  
**Sizes:** 1/4 inch to 54 inches (6 mm to 1400 mm)  
**Min. Conductivity:** ≥ 5 micromhos/cm  
**Accuracy:**  
 ± 0.25 percent of rate for velocities greater than 1.64 ft/s (0.50 m/s)  
 ± 0.004 ft/s (± 0.001 m/s) for velocities less than 1.64 ft/s (0.50 m/s)  
**Electrode Materials:** Standard: Alloy C  
 Optional: 316 stainless steel, gold/platinum plated, tantalum, platinum/rhodium  
**Liner Material:** PFA up to 3/8 inch, PTFE 1/2 inch to 24 inches, Soft and Hard Rubber from 1 to 54 inches, Halar® from 14 to 40 inches  
**NSF Listed:** Models with hard rubber liner 4-inch size and up; PTFE liner - All sizes.

**Fluid Temperature:**  
 With Remote Amplifier:  
 PFA, PTFE & Halar 311°F (155°C)  
 Rubber 178°F, (80°C)  
 With Meter Mounted Amplifier:  
 PFA, PTFE & Halar 212°F (100°C)  
 Rubber 178°F, (80°C)  
**Pressure Limits:**  
 Maximum allowable non-shock pressure and temperature ratings for steel pipe flanges, according to American National Standard ANSI B16.5. (Example: 150-pound flanges, rated 285 PSI at ambient temperature.) (Example: 300-pound flange rated 740 PSI at ambient temperature.)  
**Coil Power:** Pulsed DC  
**Ambient Temperature:** -4°F to 140°F (-20°C to 60°C)

**Pipe Spool Material:** 316 stainless steel  
**Meter Housing Material:** Carbon steel welded  
**Flanges:** Carbon steel - Standard (ANSI B16.5 Class 150 RF) 316 stainless steel - Optional  
**Meter Enclosure Classification:** NEMA 4X (IP66)  
**Optional:** Submersible NEMA 6P (remote amplifier required)  
**Junction Box Enclosure Protection:**  
 (for remote amplifier option) Powder coated die-cast aluminum, NEMA 4 (IP65)  
**Cable Entries:** 1/2-inch NPT Cord Grip  
**Optional Stainless Steel Grounding Rings:**  

Meter Size	Thickness (of one ring)
up through 10 inches	.135 inch
12 to 20 inches	.187 inch

Badger and M-Series are registered trademarks of Badger Meter, Inc.

Only products bearing the NSF Mark are Certified.

Please see our Web site at  
[www.badgermeter.com](http://www.badgermeter.com)  
 for specific contacts.

© 2010 Badger Meter, Inc. All rights reserved.

Due to continuous research, product improvements and enhancements, Badger Meter reserves the right to change product or system specifications without notice, except to the extent an outstanding contractual obligation exists.



**BadgerMeter, Inc.**

P.O. Box 245036  
 Milwaukee, WI 53224-9536  
 800-876-3837

infocentral@badgermeter.com • www.badgermeter.com